

collection 2023



hand made — in Italy.

**cielo**

**THEO**

**UN GIOCO COMPOSITIVO  
FATTO DI PIANI, LINEE E CROMIE  
A COMPOSTIONAL GAME  
OF PLANES, LINES AND COLOURS**

design Andrea Parisio and Giuseppe Pezzano

**cielo**

## THEO

Ispirato al movimento De Stijl, uno dei più influenti dell'arte moderna, il progetto propone forme nate dalla ricerca della semplicità assoluta, in cui la composizione non è mai rigida, ma ricca di forza grafica. In un gioco di equilibri visivi fatto di piani, linee e cromie, Theo detta una nuova grammatica formale, in cui il colore e il design continuano a rimanere i principali protagonisti.

La nuova collezione è formata da più elementi - ampia bacinella in ceramica, mobile in Fenix su legno multistrato con bordatura a vista, ed elementi tubolari - che combinati fra loro danno vita a molteplici configurazioni. Il lavabo in ceramica presenta due versioni - Tonda e Ovale - nelle finiture bianco lucido e nelle tonalità opache e lucide delle palette cromatiche Terre e Acque di Cielo. Il mobile è declinato in sette modelli: due per le composizioni con le mensole sospese - Theo Mini e Theo 70 - e cinque per le versioni con il contenitore, che prevede tre lunghezze Theo 78, Theo 103 e Theo 175. Il mobile può essere sospeso o arricchito da un piedino in cromia con i portasciugamani. Theo 175 si articola in differenti varianti: con una o più ante e vani a giorno oppure con due cassettoni e un vano a giorno.

Per una massima personalizzazione i mobili in Fenix sono disponibili in otto colori, mentre gli elementi tubolari in metallo, nella finitura Talco, Nero Matt, Cemento e nelle palette Acque di Cielo abbinabili alla bacinella in ceramica. A completare il disegno della parete, lo specchio contenitore Theo disponibile in due versioni: Ovale, Rettangolare e Theo 60 di forma circolare e dal design essenziale.

Inspired by the De Stijl movement, one of the most influential in modern art, the project proposes forms born from the search for absolute simplicity, in which the composition is never rigid, but rich in graphic strength. In a game of visual balances made up of planes, lines and colours, Theo dictates a new formal grammar, in which colour and design remain the main protagonists.

The new collection consists of several elements - a large ceramic basin, a Fenix cabinet on multilayer plywood with visible edging, and tubular elements - which combine to create multiple configurations. The ceramic washbasin comes in two versions - Tonda and Ovale - in glossy white finishes and in the matt and glossy shades of the Terre and Acque di Cielo colour palettes. The cabinet is available in seven models:

two for the compositions with the suspended shelves - Theo Mini and Theo 70 - and five for the versions with the storage unit, which comes in three lengths Theo 78, Theo 103 and Theo 175. The cabinet can be suspended or enriched with a leg in the same colour as the towel rails. Theo 175 comes in different variants: with one or more doors and open compartments or with two drawers and an open compartment.

For maximum customisation, the Fenix furniture is available in eight colours, while the tubular metal elements are available in Talco, Matt Black, Cemento and the Acque di Cielo palettes to match the ceramic washbasin. Completing the wall design is the Theo container mirror available in two versions: Oval, Rectangular and Theo 60 with a circular shape and essential design.

**INTRODUZIONE**

**INTRODUCTION**

06

**ABACO PRODOTTI & FINITURE**

**ABACO PRODUCTS & FINISHES**

42

**THEO**

08

L'espressione made in Italy, con cui Cielo vuole accompagnare il proprio marchio, racchiude in sé quei valori che contraddistinguono l'eccellenza del "fare" italiano considerato come un vero e proprio modello di riferimento nel mondo; la qualità del design, la selezione dei materiali migliori, la cura del dettaglio, la conoscenza dell'artigianalità e la ricerca costante dell'armonia tra forma e funzione.

L'ambizione di Cielo è di diventare un laboratorio del vero Made in Italy che possa promuovere la nostra identità culturale ponendo l'uomo al centro del progetto.

## IL LABORATORIO DELLA CERAMICA THE CERAMIC WORKSHOP

The expression 'Made in Italy', with which Cielo wants to accompany its brand, encapsulates those values that distinguish the excellence of Italian 'making' considered as a true reference model in the world; the quality of design, the selection of the best materials, the attention to detail,

the knowledge of craftsmanship and the constant search for harmony between form and function.

Cielo's ambition is to become a workshop of true Made in Italy that can promote our cultural identity by placing people at the centre of the project.



design Andrea Parisio and Giuseppe Pezzano

ISPIRATO AL MOVIMENTO  
DE STIJL, THEO PROPONE  
FORME NATE DALLA RICERCA  
DI UN ASSOLUTO EQUILIBRIO.

INSPIRED BY THE DE STIJL  
MOVEMENT, THEO PROPOSES  
SHAPES BORN FROM THE SEARCH  
FOR ABSOLUTE BALANCE.

Un prodotto che coniuga con eleganza minimalismo e colore, dando vita ad un mondo di elementi geometrici e cromatici.

A product that elegantly combines minimalism and colour, creating a world of geometric and chromatic elements.





P. 10-13 Theo 152 sospeso con due ante e tre vani a giorno: lavabi tondi in ceramica finitura Talco, mobile in Fenix finitura Cotone, portasciugamani in metallo finitura Cemento. Specchi contenitori Theo Ovali in Fenix, destro e sinistro finitura Cotone. Vasca Dafne in Solid Surface: finitura Bianco Matt. Wc e bidet sospesi Enjoy: finitura Arenaria. Barra porta accessori quadrata in metallo finitura Nero Matt, con mensola porta dispenser in Solid Surface finitura Bianco Matt.

P. 10-13 Wall-hung Theo 152 with two doors and three open compartments: round ceramic washbasins in Talco finish, cabinet in Fenix with a Cotone finish, metal towel rail in Cemento finish. Oval Theo storage mirrors in Fenix, right and left in Cotone finish. Dafne bathtub in Solid Surface: Matt White finish. Enjoy suspended WC and bidet: Arenaria finish. Square, metal accessory holder bar in Matt Black finish, with dispenser holder shelf in Solid Surface: Matt White finish.

P. 15 Theo 152 con due ante e tre vani a giorno: lavabi tondi in ceramica finitura Arenaria, mobile in Fenix finitura Cotone, gambe e portasciugamani in metallo finitura Cemento. Specchi contenitori Theo Ovali in Fenix, destro e sinistro finitura Cotone.

P. 15 Theo 152 with two doors and three open compartments: round ceramic washbasins in Arenaria finish, cabinet in Fenix with Cotone finish, metal legs and towel rail with Cemento finish. Oval Theo storage mirrors in Fenix, right and left in Cotone finish.





Tre le configurazioni possibili per lo Specchio Theo Ovale: Sinistro o Destro con mensola portaoggetti laterale e Specchio Doppio con al centro un ulteriore vano. Lo Specchio Theo Rettangolare propone un'anta portaoggetti laterale aggiuntiva che garantisce la massima organizzazione dello spazio. Anche qui il colore è presente e valorizza gli elementi strutturali degli specchi realizzati in Fenix e personalizzabili nelle stesse otto nuance del mobile.

Three possible configurations for the Oval Theo Mirror: Left or Right with a lateral storage shelf and Double Mirror with an additional compartment in the centre. The Theo Rectangular Mirror offers an additional side storage door guaranteeing maximum organisation of space. Colour is also present here and enhances the structural elements of the mirrors made of Fenix and customisable in the same eight nuances as the furniture.

Specchi contenitori Theo Ovali in Fenix, destro e sinistro finitura Cotone.

Oval Theo storage mirrors in Fenix, right and left in Cotone finish.





P. 18 Theo 175 con due cassettoni e un vano a giorno: lavabi ovali in ceramica finitura Avena, mobile in Fenix finitura Carminio, gambe e portasciugamani in metallo finitura Corallo. Specchi contenitori Theo Ovali in Fenix, destro e sinistro finitura Carminio. Mensola Tonda: finitura Nero Matt, piano in vetro. Wc e bidet sospesi Era: finitura Avena. Mensola Ovale: finitura Nero Matt, piano in vetro. Portasciugamani Ovale 30: finitura Nero Matt.

P. 18 Theo 175 with two big drawers and one open compartment: oval ceramic washbasins in Avena finish, cabinet in Fenix with Carminio finish, metal legs and towel rail in Corallo finish. Oval Theo storage mirrors in Fenix, right and left in Carminio finish. Tonda shelf: Matt Black finish, glass top. Era suspended WC and bidet: Avena finish. Oval Shelf: Matt Black finish, glass top. Oval Towel Holder 30: Matt Black finish.

P. 20 Theo 175 con due cassettoni e un vano a giorno: lavabi ovali in ceramica finitura Corallo, mobile in Fenix finitura Carminio, gambe e portasciugamani in metallo finitura Corallo. Specchi contenitori Theo Ovali in Fenix, destro e sinistro finitura Carminio. Mensola Tonda: finitura Nero Matt, piano in vetro.

P. 20 Theo 175 with two big drawers and an open compartment: oval ceramic washbasins with Corallo finish, cabinet in Fenix with Carminio finish, metal legs and towel rail in Corallo finish. Oval Theo storage mirrors in Fenix, right and left in Carminio finish. Tonda shelf: Matt Black finish, glass top.

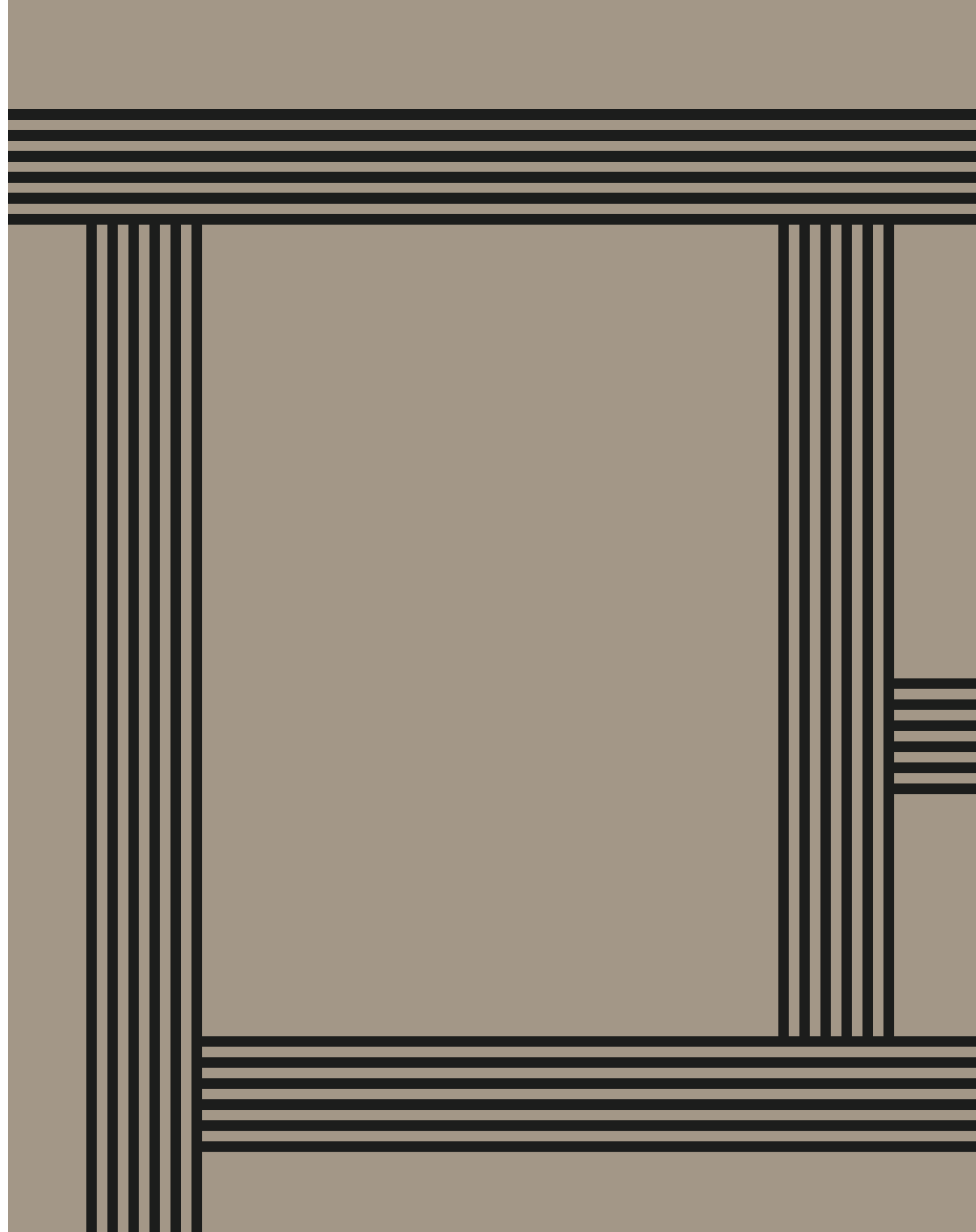

design Andrea Parisio and Giuseppe Pezzano

UN PRODOTTO CHE CONIUGA  
MINIMALISMO E COLORE,  
DANDO VITA AD UN MONDO  
DI PIANI, LINEE E CROMIE.

A PRODUCT THAT COMBINES  
MINIMALISM AND COLOUR,  
GIVING LIFE TO A WORLD OF  
PLANES, LINES AND COLOURS.

La forza espressiva di ogni elemento della collezione unita alle molteplici personalizzazioni confermano la straordinaria capacità di Ceramica Cielo di affermarsi come azienda innovatrice nella lavorazione della ceramica in abbinamento ad altri materiali, e portavoce della tradizione produttiva handmade in Italy.

The expressive power of each element in the collection combined with the multiple customisations confirm Ceramica Cielo's extraordinary ability to establish itself as an innovative company in the processing of ceramics in combination with other materials, and a spokesperson for the handmade in Italy production tradition.





Theo 103: lavabo ovale in ceramica finitura Anemone, mobile in Fenix finitura Juta, gamba e portasciugamani in metallo finitura Anemone. Specchio contenitore Round Box 75: finitura Cemento. Vasca Cibebe L in Solid Surface finitura Bianco Matt. Wc e bidet a terra Era: finitura Talco. Mensola Tonda: finitura Anemone, piano in vetro. Portasciugamani Ovale 30: finitura Nero Matt.

Theo 103: oval ceramic washbasin in Anemone finish, cabinet in Fenix with Juta finish, metal legs and towel rail in Anemone finish. Round Box 75 container mirror: Cemento finish. Cibebe L Bathtub in Solid Surface: Matt White finish. Era floor-standing WC and bidet: Talco finish. Tonda shelf: Anemone finish, glass top. Oval Towel Holder 30: Matt Black finish.





Theo singolo si presenta nelle due dimensioni: da 78 con bacinella tonda e da 103 con bacinella ovale. Entrambi sono caratterizzati da un ampio vano chiuso e da mensole a giorno. A completare la composizione del mobile lavabo, abbiamo gli elementi in metallo che riprendono le cromie di Cielo. Nella versione solo mensola Theo offre un piano d'appoggio con il portasciugamani laterale integrato.

Theo single comes in two sizes: 78 with round basin and 103 with oval basin. Both feature a large, closed compartment and open shelves. To complete the composition of the washbasin unit, we have the metal elements that pick up on the Cielo colours. In the shelf-only version Theo offers a shelf with integrated side towel rail.

Theo 78: lavabo tondo in ceramica finitura Ninfea, mobile in Fenix finitura Grafite, gamba e portasciugamani in metallo finitura Ninfea. Specchio contenitore Theo rettangolare in Fenix: finitura Grafite. Wc e bidet a terra Smile 53: finitura Ninfea.

Theo 78: round ceramic washbasin in Ninfea finish, cabinet in Fenix in Grafite finish, metal legs and towel rail in Ninfea finish. Theo rectangular container mirror in Fenix: Grafite finish. Smile 53 floor-standing WC and bidet: Ninfea finish.







Theo 70: lavabo tondo in ceramica finitura Muschio, mensola in Fenix finitura Felce. Specchio Theo con gancio.

Theo 70: round ceramic washbasin in Muschio finish, shelf in Fenix in Felce finish. Theo mirror with hook.

Nella versione Mini, Theo si presenta con la sola mensola e il portasciugamano, e le sue dimensioni ridotte lo rendono adattabile a qualsiasi spazio senza perdere l'efficacia grafica e funzionale.

In the Mini version, Theo is presented with only the shelf and towel rail, and its reduced dimensions make it adaptable to any space without losing its graphic and functional effectiveness.

Theo Mini: lavabo in ceramica finitura Talco, mensola in Fenix finitura Cotone.

Theo Mini: ceramic washbasin in Talco finish, shelf in Fenix in Cotone finish.





ABACO PRODOTTI & FINITURE  
ABACO PRODUCTS & FINISHES

## LA TECNOLOGIA RIVOLUZIONA IL DESIGN

FENIX è un materiale innovativo costituito per il 60% da carta e per il 40% da resine. È realizzato attraverso un particolare processo in cui il calore e la pressione vengono applicati simultaneamente al fine di ottenere un prodotto omogeneo e non poroso. La superficie è estremamente opaca e anti-impronta, piacevolmente morbida al tatto.

Grazie alla nanotecnologia applicata su FENIX si ha una resistenza superiore ai graffi superficiali e all'abrasione. Le proprietà di elevata resistenza di FENIX sono ottenute grazie all'utilizzo di particelle molto piccole (nanoparticelle) tali da non essere visibili ad occhio nudo. Tramite un processo produttivo altamente tecnologico, le nanoparticelle vengono uniformemente distribuite e incorporate nel rivestimento superficiale di FENIX.

Pannello in Multistrati di betulla fenolico, rivestito bifacciale in FENIX con bordi a vista con vernice trasparente opaca. La scelta di lasciare il multistrati a vista, oltre a caratterizzare dal punto di vista estetico il prodotto, garantisce una maggior resistenza allo stesso.

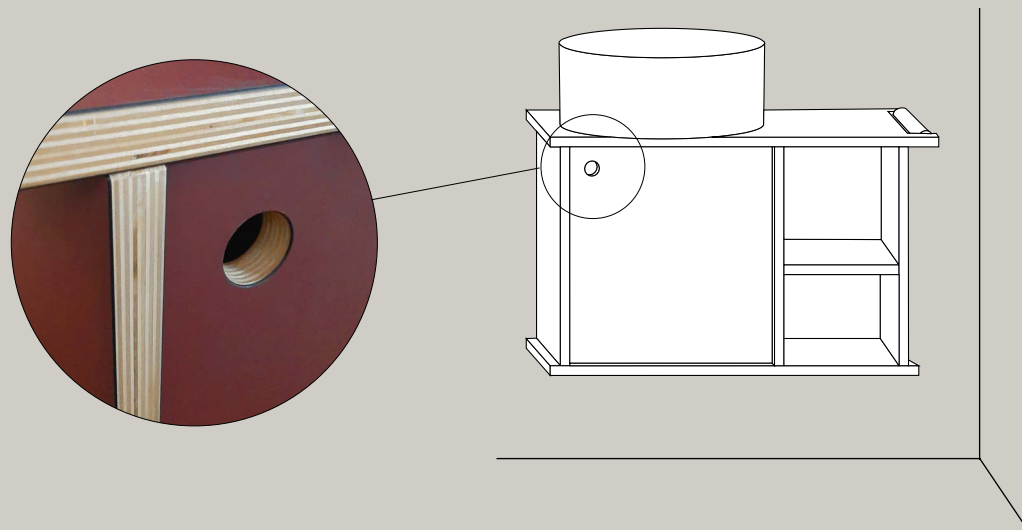

### TECHNOLOGY REVOLUTIONISES DESIGN

FENIX is an innovative material consisting of 60% paper and 40% resins. It is manufactured through a special process in which heat and pressure are applied simultaneously in order to obtain a homogenous, non-porous product. The surface is extremely opaque, anti-fingerprint and pleasantly soft to the touch. Thanks to the nanotechnology applied to FENIX, there is superior resistance to surface scratches and abrasion. The high

resistance properties of FENIX are achieved by the use of very small particles (nanoparticles) that are not visible to the naked eye. Through a high-tech production process, the nanoparticles are uniformly distributed and incorporated into the surface coating of FENIX. A phenolic birch plywood panel, double-sided coated in FENIX with visible edges with transparent matt varnish. The decision to leave the plywood visible, in addition to characterising it from an aesthetic point of view, guarantees greater resistance.

## LE FINITURE

Per Theo abbiamo selezionato una gamma di colori del FENIX che perfettamente si abbina alle nostre finiture ceramiche, creando molteplici possibilità di personalizzazioni.

I componenti in metallo (gambe opzionali e portasciugamani) possono essere realizzati in Nero Matt, Cemento o nei colori lucidi delle Acque di Cielo, creando illimitati giochi cromatici con il lavabo in ceramica e il mobile.

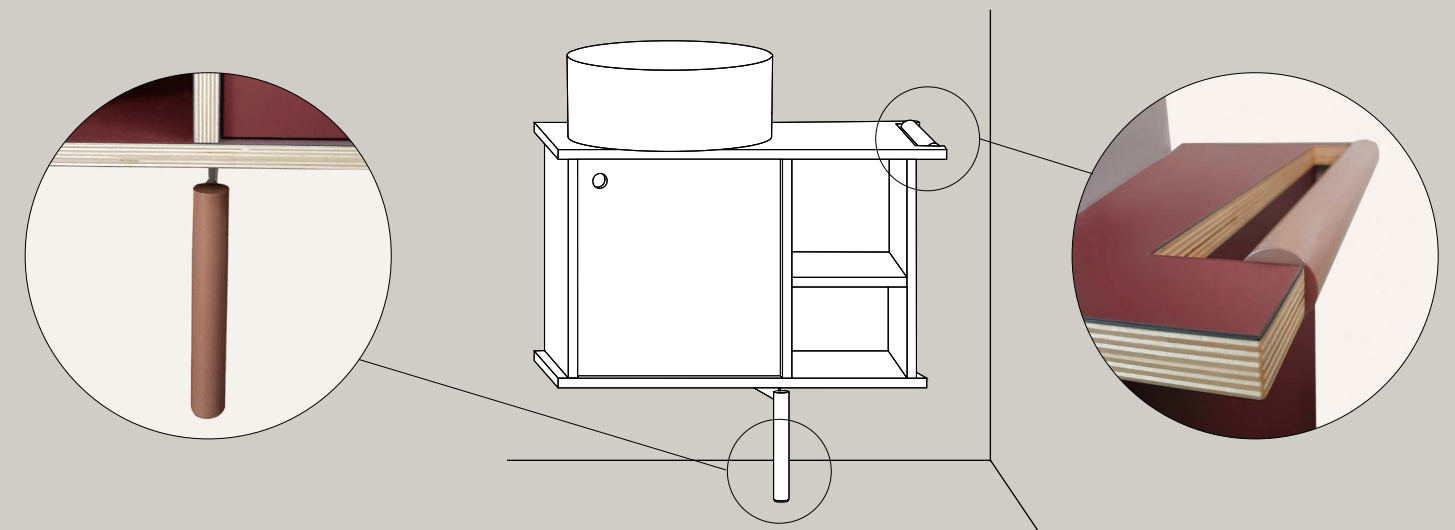

### FINISHES

For Theo we have selected a range of FENIX colours that perfectly match our ceramic finishes, creating multiple customisation possibilities. The metal components

(optional legs and towel rails) can be made in matt black, Cemento or the glossy colours of the Acque di Cielo, creating unlimited chromatic effects with the ceramic washbasin and cabinet.

## LAVABO WASHBASIN

CERAMICA / CERAMIC  
LE ACQUE DI CIELO



CERAMICA / CERAMIC



CERAMICA / CERAMIC  
LE TERRE DI CIELO



## MOBILE CABINET

FENIX

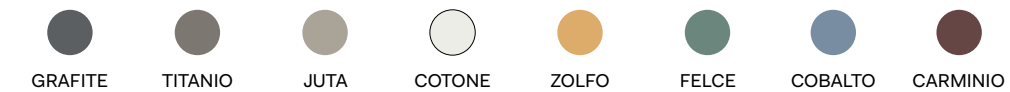

## PORTASCIUGAMANI E GAMBA TOWEL RAIL AND METAL LEG

METALLO / METAL



METALLO / METAL  
LE ACQUE DI CIELO



## THEO MINI

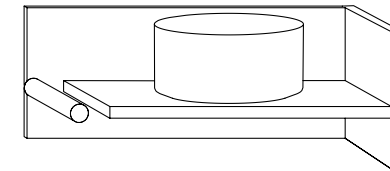

THEO MINI  
cm 55 x 38 x 24 h

## THEO 70

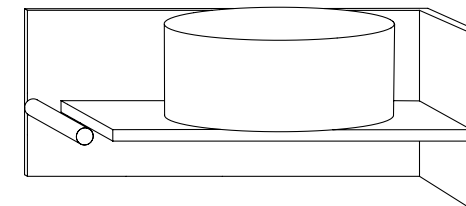

THEO MINI  
cm 72 x 38 x 29 h

## LAVABO WASHBASIN

CERAMICA / CERAMIC  
LE ACQUE DI CIELO



CERAMICA / CERAMIC



CERAMICA / CERAMIC  
LE TERRE DI CIELO



## MOBILE CABINET

FENIX



## PORTASCIUGAMANI E GAMBA TOWEL RAIL AND METAL LEG

METALLO / METAL

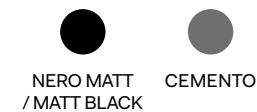

METALLO / METAL  
LE ACQUE DI CIELO



Il mobile è predisposto per installazione sia a terra che sospesa.  
Composizione obbligatoria:  
lavabo + mobile + portasciugamani.  
Le gambe sono solo per la versione del mobile a terra.

/ The furniture is suitable for both floor and hanging installation.  
Mandatory composition:  
basin+ furniture + towel rail.  
Legs are for floor furniture only.

## THEO 78

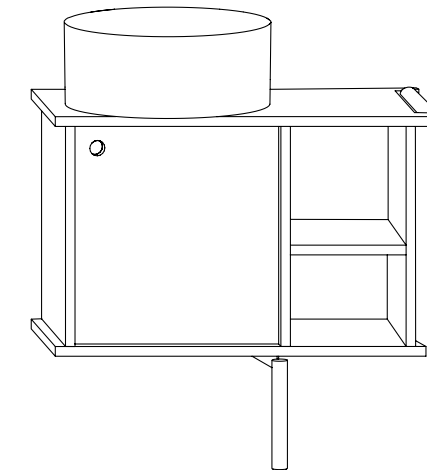

THEO 78  
cm 78 x 38 x 87 h

## THEO 103

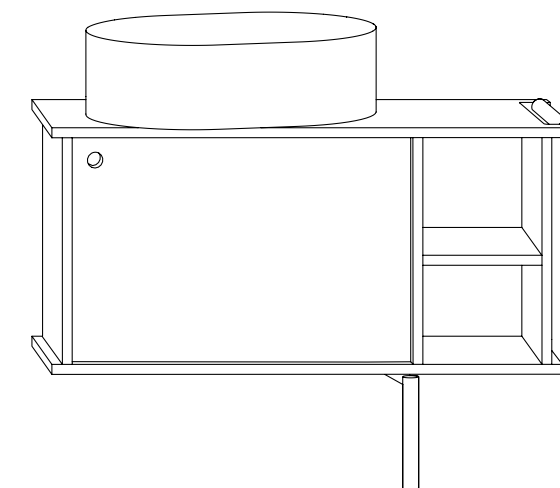

THEO 103  
cm 103 x 38 x 87 h

## LAVABO WASHBASIN

CERAMICA / CERAMIC  
LE ACQUE DI CIELO



CERAMICA / CERAMIC



CERAMICA / CERAMIC  
LE TERRE DI CIELO



## MOBILE CABINET

FENIX



## PORTASCIUGAMANI E GAMBA TOWEL RAIL AND METAL LEG

METALLO / METAL

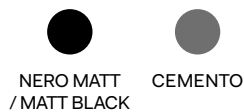

METALLO / METAL  
LE ACQUE DI CIELO



Il mobile è predisposto per installazione sia a terra che sospesa.  
Composizione obbligatoria:  
lavabo + mobile + portasciugamani.  
Le gambe sono solo per la versione del mobile a terra.

/ The furniture is suitable for both floor and hanging installation.  
Mandatory composition:  
basin+ furniture + towel rail.  
Legs are for floor furniture only.

## THEO 175

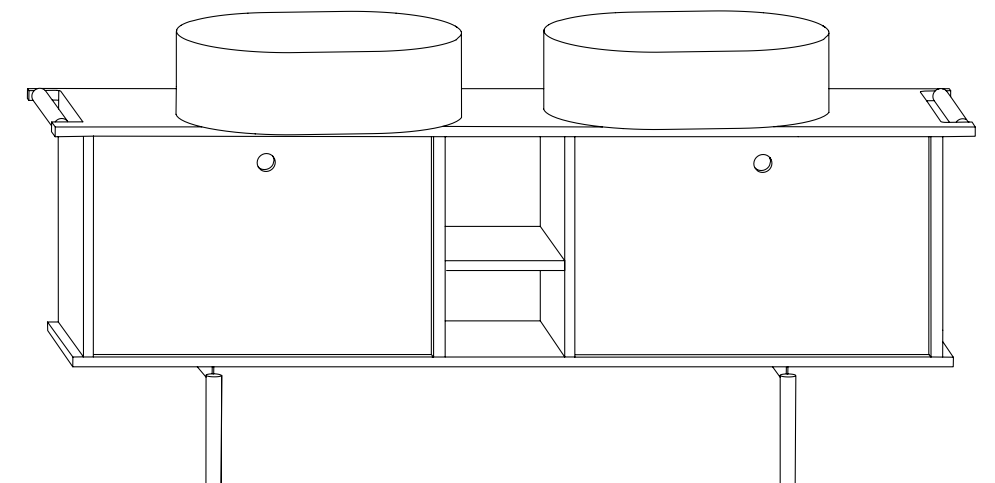
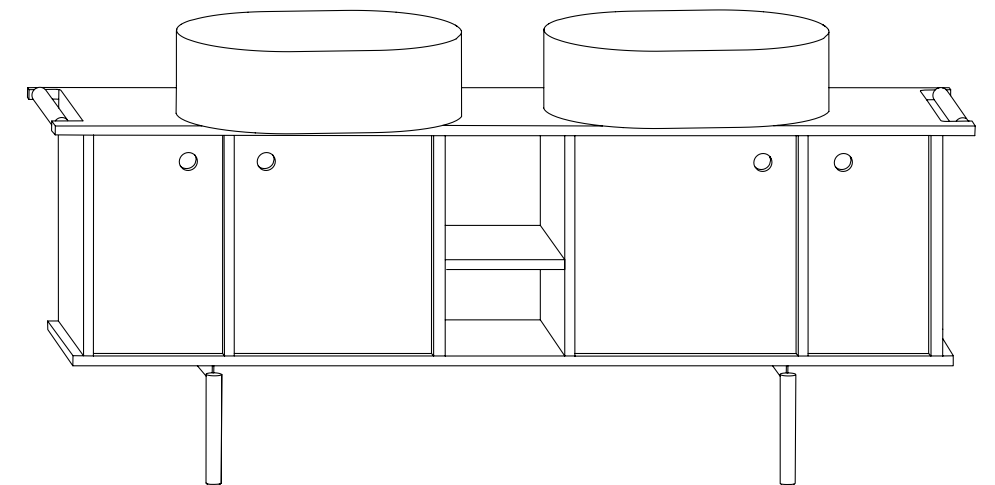
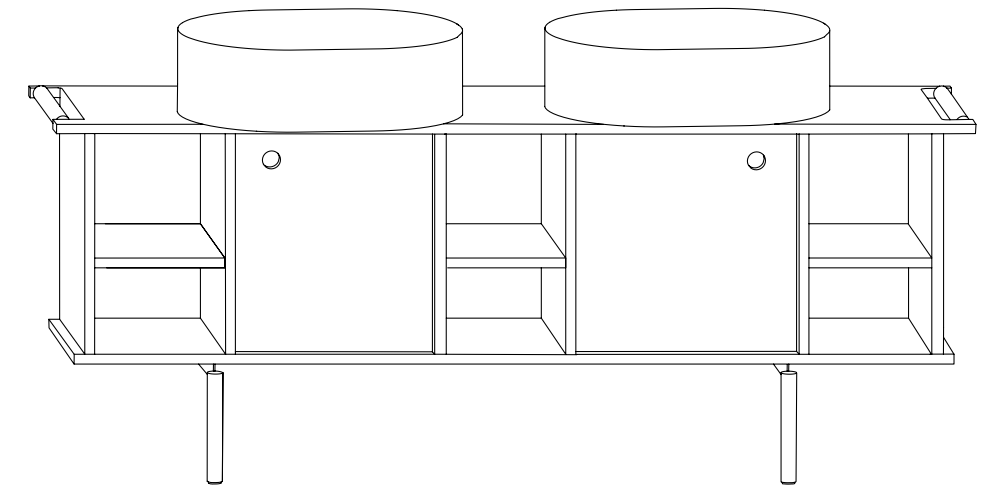

THEO 175  
con 2 ante e 3 vani giorno  
/ with 2 doors and 3 open  
compartments  
cm 175 x 38 x 87 h

THEO 175  
con 4 ante e un vano giorno  
/ with 4 doors and an open  
compartment  
cm 175 x 38 x 87 h

THEO 175  
con 2 ante e un vano giorno  
/ with 2 doors and an open  
compartment  
cm 175 x 38 x 87 h

## LAVABI / WASHBASINS

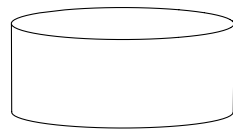

LAVABO TONDO THEO  
Theo round washbasin  
cm 40 x 40 x 16 h

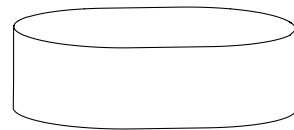

LAVABO OVALE THEO  
Theo oval washbasin  
cm 55 x 40 x 16 h

CERAMICA / CERAMIC  
LE ACQUE DI CIELO



CERAMICA / CERAMIC



CERAMICA / CERAMIC  
LE TERRE DI CIELO



## SPECCHIO THEO 60 / THEO 60 MIRROR

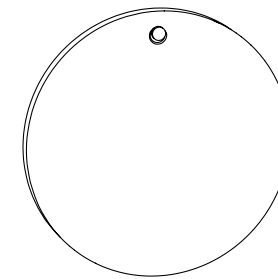

THEO 60  
cm Ø60 x 3,5

GANCIO  
HOOK

METALLO / METAL  
LE ACQUE DI CIELO

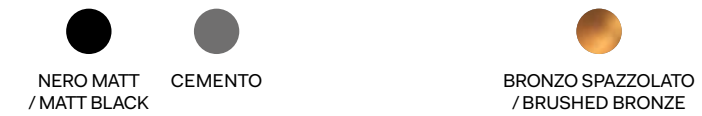

METALLO / METAL

CORNICE  
FRAME

LACCATURE / LACQUERING

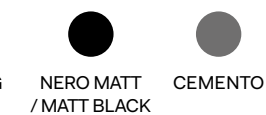

MULTISTRATI / PLYWOOD



SPECCHI CONTENITORI / MIRRORS WITH CABINET

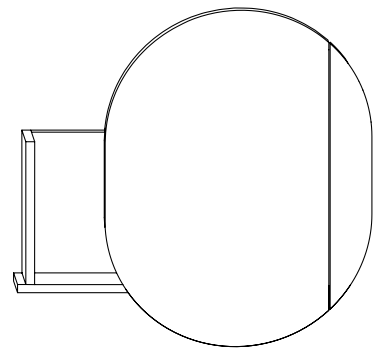

THEO DESTRO  
Theo right mirror  
cm 80 x 13 x 78 h

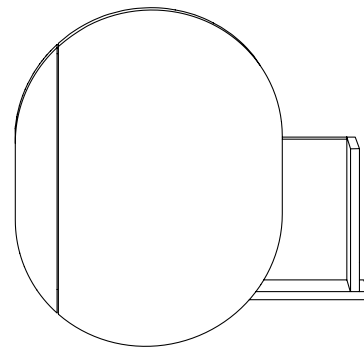

THEO SINISTRO  
Theo left mirror  
cm 80 x 13 x 78 h

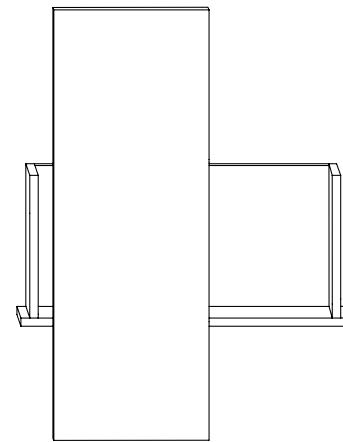

THEO RETTANGOLARE  
Theo rectangular  
cm 74 x 12,5 x 100 h

FENIX



GRAFITE



TITANIO



JUTA



COTONE



ZOLFO



FELCE



COBALTO



CARMINIO

SPECCHI CONTENITORI / MIRRORS WITH CABINET

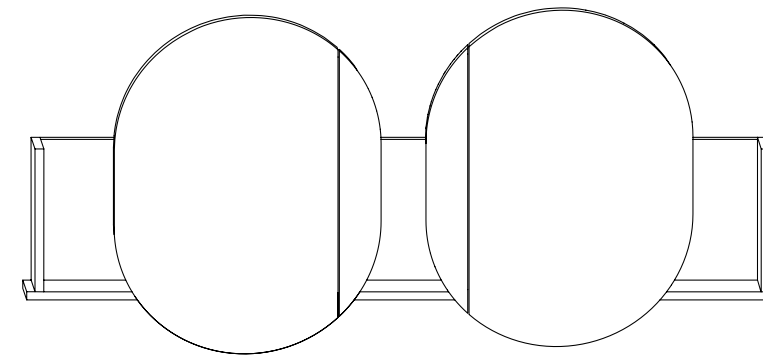

THEO DOPPIO  
Theo double mirror  
cm 167 x 13 x 78 h

FENIX



GRAFITE



TITANIO



JUTA



COTONE



ZOLFO



FELCE



COBALTO



CARMINIO

Marzo / March 2023

Ceramica Cielo Spa

A.D.

Andrea Parisio

Giuseppe Pezzano

A.D. Progetto Grafico / Graphic Project

VZNstudio (Nicola Iannibello e Sonia Mion)

Fotografie / Photos

Thomas Pagani

Davide Lovatti (P. 39-40)

Styling

Alessandra Vigani

Fotolito e stampa / Photolith and press

Telligraf

Thanks to Italgraniti

© Tutti i diritti sono riservati.

Nessuna parte di questo catalogo può essere riprodotta o trasmessa in qualsiasi forma o con qualsiasi mezzo elettronico, meccanico o altro senza l'autorizzazione scritta dei proprietari dei diritti.

© All rights reserved.

No part of this catalogue may be reproduced or transmitted in any form or by any electronic, mechanical or other means without the written permission of the owners of the rights.

# cielo

## **Ceramica Cielo S.p.A.**

Via Falerina Km 7,800

01034 - Fabrica di Roma (VT) Italy

t +39 076156701 \ f +39 0761540363

info@ceramicacielo.it

## **Spazio Cielo**

Via Pontaccio 4 \ 6

20121 - Milano Italy

t +39 0239661165

milano@ceramicacielo.it

[www.ceramicacielo.it](http://www.ceramicacielo.it)